



VP6800[®] User Manual



80159500-001 Rev X
25 February 2022

ID TECH[®]
10721 Walker Street Cypress, CA 90630
(714) 761-6368
www.idtechproducts.com support@idtechproducts.com

Copyright © 2022 ID TECH. All rights reserved.

This document, as well as the software and hardware described in it, is furnished under license and may be used or copied online in accordance with the terms of such license. The content of this document is furnished for information use only, is subject to change without notice, and should not be construed as a commitment by ID TECH®. While every effort has been made to ensure the accuracy of the information provided, ID TECH assumes no responsibility or liability for any unintentional errors or inaccuracies that may appear in this document. Except as permitted by such license, no part of this publication may be reproduced or transmitted by electronic, mechanical, recording, or otherwise, or translated into any language form without the express written consent of ID TECH.

ID TECH and ViVOPay® are trademarks or registered trademarks of ID TECH.

Warranty Disclaimer

The services and hardware are provided "as is" and "as-available" and the use of the services and hardware are at its own risk. ID TECH does not make, and hereby disclaims, any and all other express or implied warranties, including, but not limited to, warranties of merchantability, fitness for a particular purpose, title, and any warranties arising from a course of dealing, usage, or trade practice. ID TECH does not warrant that the services or hardware will be uninterrupted, error-free, or completely secure.

FCC warning statement

This device complies with Part 15 of the FCC Rules. Operation is subject to the following two conditions: (1) this device may not cause harmful interference, and (2) this device must accept any interference received, including interference that may cause undesired operation.

The user manual for an intentional or unintentional radiator shall caution the user that changes, or modifications not expressly approved by the party responsible for compliance could void the user's authority to operate the equipment.



Note: The grantee is not responsible for any changes or modifications not expressly approved by the party responsible for compliance. Such modifications could void the user's authority to operate the equipment.

Note: This equipment has been tested and found to comply with the limits for a Class B digital device, pursuant to part 15 of the FCC Rules. These limits are designed to provide reasonable protection against harmful interference in a residential installation. This equipment generates uses and can radiate radio frequency energy and, if not installed and used in accordance with the instructions, may cause harmful interference to radio communications. However, there is no guarantee that interference will not occur in a particular installation. If this equipment does cause harmful interference to radio or television reception, which can be determined by turning the equipment off and on, the user is encouraged to try to correct the interference by one or more of the following measures:

- Reorient or relocate the receiving antenna.
- Increase the separation between the equipment and the receiver.
- Connect the equipment into an outlet on a circuit different from that to which the receiver is connected.
- Consult the dealer or an experienced radio/TV technician for help.

This device complies with FCC RF radiation exposure limits set forth for an uncontrolled environment. The antenna(s) used for this transmitter must not be co-located or operating in conjunction with any other antenna or transmitter. This device should be installed to provide a separation distance of at least 20cm from a person.

Cautions and Warnings

	<p>Caution: Use standard USB 5V power source for USB operation. Use approved power source for RS-232 operation. Device contains a lithium battery. Approved temperature range for storage: -40°C to +80°C. Disposal: Contact your local recycling center.</p>
	<p>Warning: Avoid close proximity to radio transmitters, which may reduce the capabilities of the reader.</p>

Revision History

Date	Rev	Changes	Author
03/30/2021	U	Reimplemented Revision History Added Tamper and Failed Self-Check Indicators section Multiple updates for readability—specifically, condensed section and Basic Operations sections Added Durability section to Specifications Added LED indicator specs Updated Agency Approvals and Compliances list Added card interface insertion/tap diagram	CB
04/22/2021		Updated power supply part number Added power supply photo to section 7.1	CB
05/07/2021	V	Added Grounding Requirements to Installation section.	CB
02/25/2022	X	Added mounting angle instructions for drainage purposes.	CB

Table of Contents

1. OVERVIEW	6
1.1. Integration Location	6
1.2. Integration Options.....	6
1.3. Encryption.....	6
2. FEATURES.....	7
2.1. Agency Approvals and Compliances.....	8
3. SPECIFICATIONS	9
4. COMMUNICATIONS	10
4.1. Audio Support	10
5. CABLE.....	11
6. BASIC OPERATION	12
6.1. VP6800 Card Interfaces	12
6.2. LEDs and LCD Status Indicators	13
6.3. Device State and UI.....	13
6.4. Tamper and Failed Self-Check Indicators.....	14
6.4.1. <i>Other Status Messages</i>	15
7. INSTALLATION	16
7.1. Parts List for Development.....	16
7.2. VP6800 Mounting Guidelines and Installation	17
7.2.1. <i>VP6800 Mounting Angle Requirements</i>	18
7.3. VP6800 Grounding Requirements.....	19
7.4. Connecting Cable and Power.....	19
7.5. Bluetooth Connection	20
8. VP6800 CONFIGURATION SETTINGS.....	21
8.1. Configuring Ethernet Settings.....	22
8.1.1. <i>Setting the Device IP</i>	23
8.1.2. <i>Setting the Remote IP</i>	23
8.2. Configuring Wi-Fi Settings.....	25
8.2.1. <i>Setting the Device IP</i>	26
8.2.2. <i>Setting the Remote IP</i>	26
8.2.3. <i>Setting the SSID and Password</i>	27
8.3. Configuring BLE Settings.....	28
8.3.1. <i>Selecting Wi-Fi or Bluetooth</i>	29
9. SECURITY GUIDE	30
10. DECOMMISSIONING PCI-CERTIFIED DEVICES.....	31
11. TROUBLESHOOTING	31
12. 24-HOUR DEVICE REBOOT	31
13. FIRMWARE REFERENCE.....	31
14. SOFTWARE DEVELOPMENT SUPPORT	31
15. UPDATING VP6800 FIRMWARE	32
16. APPENDIX A: POWER OVER ETHERNET SPLITTER	35
16.1. ID TECH POE Splitter	35
17. APPENDIX B: SUPPORTED MICRO SD CARDS.....	35

1. Overview

The all-new VP6800 by ID TECH is a state-of-the-art, 3-in-1, PCI PTS 5.x certified unattended payment device that can accept magstripe, chip card (EMV), and/or NFC/contactless payments. The unit features a 4.3-inch high-luminosity color touchscreen display capable of supporting PIN-on-glass transactions and can also display video advertisements when it is not being used for menu displays or customer interactions.

The VP6800 accepts all of today's most popular payment methods, including those based on digital wallet technology, including Apple Pay, Android Pay, and Samsung Pay, along with support for loyalty technologies such as Apple Pay VAS and Google Pay SmartTap. The VP6800 is suitable for payment solutions involving:

- Transportation
- Vending
- Parking
- Quick Service Restaurants
- POS Kiosks

1.1. Integration Location

The VP6800 is the next generation vending payment peripheral in the popular ID TECH Vending line (including Vendi and VP6300) of unattended contactless payment hardware. This device is intended to be deployed on unattended kiosks, parking systems, and vending machines that support a variety of different payment methods, digital advertising, and guidance using visual payment prompts.

1.2. Integration Options

ID TECH provides a feature-rich Universal SDK to aid rapid development of external (non-device-resident) payment applications that talk to the VP6800. The Universal SDK is available for the C# language on Windows and comes with sample code for demo apps. To obtain the SDK and other useful utilities, demos, and downloads for the VP6800, be sure to check the Downloads link on the [ID TECH Knowledge Base](#) (no registration required).

1.3. Encryption

The VP6800 supports industry-standard Triple DES or AES encryption technology, with DUKPT-based key management (per ANSI X.9-24). Encryption can be configured to occur with a PIN variant key, or Data variant, as desired. ID TECH operates a certified Key Injection Facility, capable of injecting your unit(s) with any required keys. Remote Key Injection (RKI) is also available. Consult your ID TECH representative to learn about all available options involving key injection.

As a PCI-validated SRED device, the VP6800 conducts periodic self-checks and incorporates tamper detection features which, if triggered, cause automatic zeroization of sensitive data and keys. Because of its SRED features, the VP6800 is fully capable of being incorporated into a P2PE certified solution.

2. Features

- 4.3-inch color digital display (480 x 272 pixels)
- Supports PIN on glass
- Concealed contactless antenna
- PCI PTS 5.x certified with SRED validation
- Connectivity interface – RS-232, USB 2.0 via micro-USB, Ethernet 10/100M¹, and optional Wi-Fi/BLE
- 3.5mm audio jack
- Optional camera or 2D scanner
- Supports EVA standard external mounting
- Support for contactless loyalty protocols (Apple Pay VAS, Google Pay Smart Tap 2.1)
- Contactless payments (Apple Pay, Google Pay, Samsung Pay)
- Supports the latest EMV Contactless L2 kernels: AMEX, Discover, Interac, JCB, Mastercard, Visa & Union Pay
- Environmental certifications (RoHS, REACH, RED)
- Encryption support (TDES, AES, DUKPT)
- Remote Key Injection Support (PCI validated)
- Firmware upgradeable in the field

¹ Note: the VP6800 must be power-cycled to switch between 10M and 100M.

2.1. Agency Approvals and Compliances

- CE
- EMV Contact L1 & L2
- EMV Contactless L1
- EMV Contactless L2s:
 - Amex
 - Discover
 - Interac
 - JCB
 - MasterCard
 - UPI
 - Visa
- FCC (Part 15, Class-B)
- FelCa
- MIC (Japan)
- PCI 5.X
- REACH
- RoHS3
- Telec (Japan)
- UL
- USB 2.0

3. Specifications

Hardware	
CPU	528 MHz application processor
Memory	256Mb SDRAM, 1Gb NAND flash
Camera	5 megapixels
SAMs	2 slots
SD card slot	1 slot
Audio	3.5mm audio jack
Interface	USB, RS232, Ethernet, BLE/Wi-Fi
Power Supply	+5VDC 2A
Power Consumption	Active Power mode: 3.5w Sleep mode: <0.5w
Physical	
Length	140 mm
Width	95 mm
Depth	52.1 mm
Screen	
Dimensions (in pixels)	480 (height) x 272 (width)
Luminance/Brightness	900 cd/m ²
Touch Interface Type	Capacitive
Environmental	
Operating Temperature	-25° C to 70° C (-13° F to 158° F), max change of 10° C per hour
Storage Temperature	-40° C to 80° C (-40° F to 176° F)
Operating Humidity	Up to 95% non-condensing
Storage Humidity	10% to 90% non-condensing, duration three months
IK Rating	IK 08
IP Rating	IP 65
Durability	
MBTF	200,000 POH
MSR Swipe Durability	500,000 times
ICC Connector Reliability	500,000 times

Note: Boot-up time can vary for VP6800 readers depending on configuration; boot-up is usually complete within 15 seconds. "Power On" is defined as the length of time from pressing the power button to the screen displaying the ID TECH logo; "Wake Up" is defined as the length of time from tapping the screen to the screen displaying the ID TECH logo.

Mode	Boot Up Time	
	Average	Maximum
Power On	7s	15s
Wake Up from Sleep Mode	0.5s	1s
Wake Up from Stop Mode ²	7s	15s

² Stop Mode is a low-power version of Sleep Mode. It consumes less power than Sleep Mode but requires a soft reboot to wake up from sleeping.

4. Communications

The VP6800 can communicate with a host via serial (RS-232), Wi-Fi, Bluetooth, USB, or Ethernet connections. The diagram below illustrates the layout of various ports.

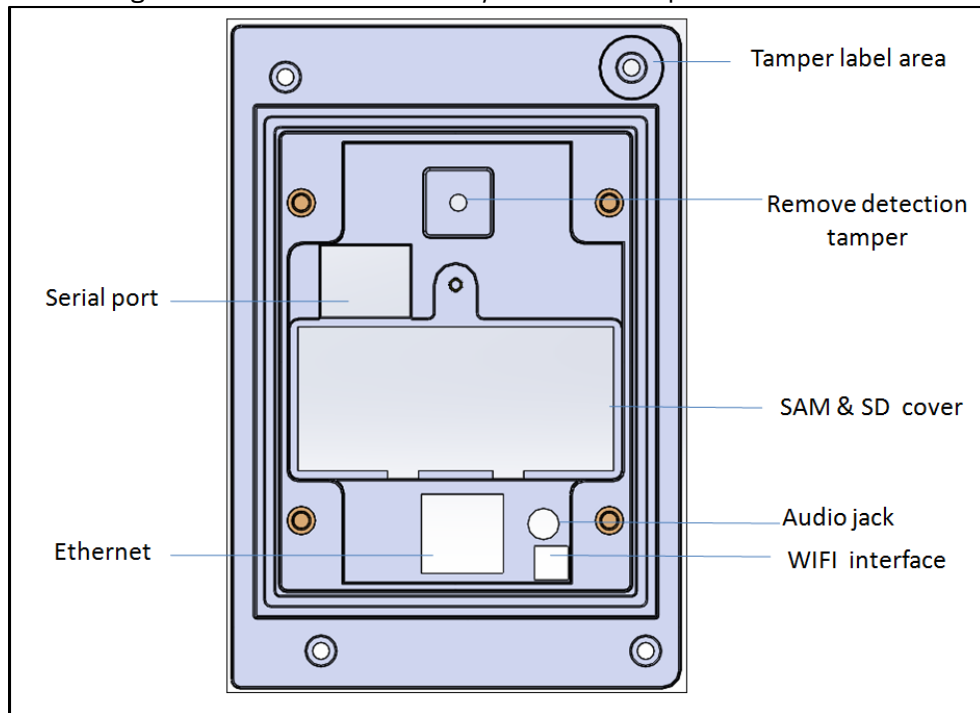

4.1. Audio Support

While the VP6800 does not have an internal speaker, it can host 16mb .WAV files and connect to an external speaker via the 3.5mm audio jack.

5. Cable

The VP6800 uses a serial port to USB +RS-232+RS-232 cable. The cable connectors follow the schematic illustrated below.

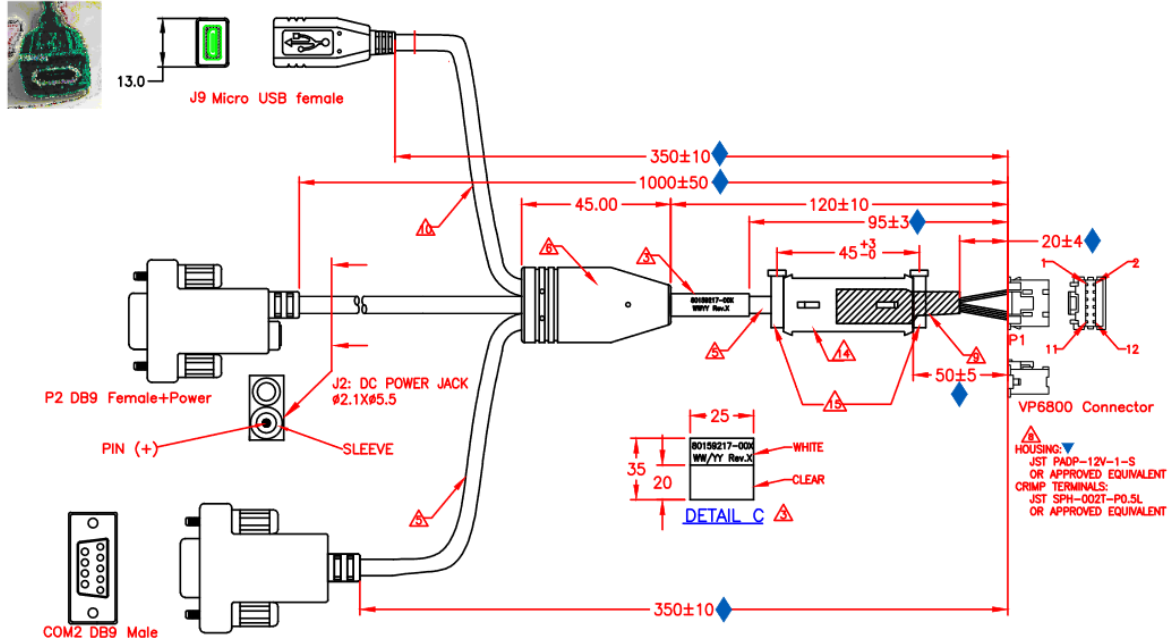

DB9 Male	DB9 Female+Power	Micro USB female	VP6800 Connector		
COM2	P2	J9	SIGNAL	COLOR	P1
-	-	PIN (+)RED	+5V_OUT	RED	1
3 YELLOW	-	-	RS232B_TX2	YELLOW	2
2 WHITE	-	-	RS232B_RX2	BROWN	3
-	3 YELLOW	-	RS232A_RX1	BLUE	4
-	2 WHITE	-	RS232A_TX1	PURPLE	5
-	-	4 BLACK	USB ID	LIGHT BLUE	6
SHIELD GND	SHIELD GND	SHIELD GND	GND_EARTH	GND	7
-	-	1 RED	OTG 5V OUT	ORANGE	8
5 BLACK	5 BLACK	SLEEVE BLACK	GND	BLACK	9
-	-	-	USB D-	WHITE	10
5 BLACK	5 BLACK	SLEEVE BLACK	GND	GREY	11
-	-	3 GREEN	USB D+	GREEN	12

Note: For development purposes, ID TECH can supply a serial port interface cable that supports RS-232 or USB. If you wish to develop your own cable, ID TECH uses a JST PADP-12v-1-S housing with JST-SPH-002T-P0.5L crimp terminals. See the schematic above for pin outs.

6. Basic Operation

When powered on, the VP6800 boots automatically and illuminates within about five seconds. For development purposes, use cable P/N 80159217-001. Plug the 12-pin Molex connector into the back of the VP6800, and supply 5VDC 2A power (via cannon connector at the powered DB9 connection) using an ID TECH P/N AC0005R-26 or equivalent power supply. Optionally also connect a standard Ethernet cable between the RJ45 ports on the back of the VP6800 and the network port of the host system.

6.1. VP6800 Card Interfaces

VP6800 readers have the following card interface points, shown below.

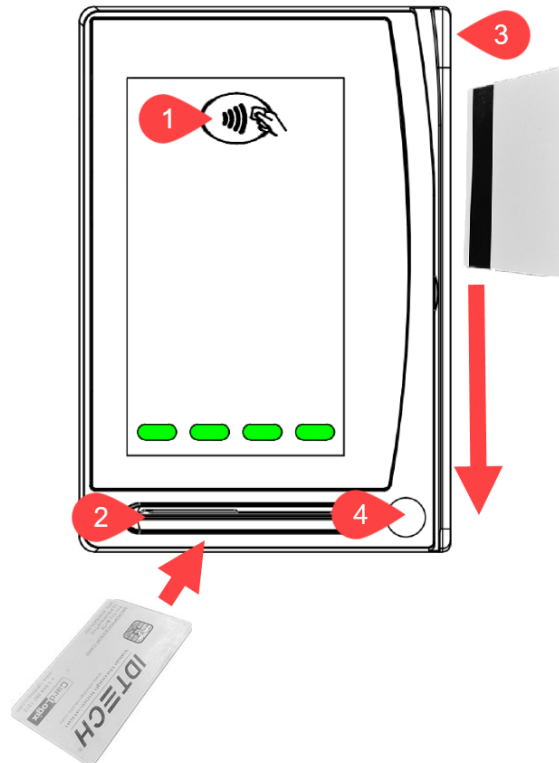

Interface	Note
1. Contactless antenna	
2. ICC slot	Smart chip must face upward for ICC transactions.
3. MSR slot	MagStripe must face left for MSR swipes.
4. QR Code camera	

6.2. LEDs and LCD Status Indicators

The VP6800 uses LEDs and the main LCD display to denote its status during transactions and in case of errors. The small LED lights beside the main digital display used during a contactless transaction. Contactless LED lights also appear on the digital display.



LED and Behavior	Status Indicated
First left virtual LED blink green regularly	VP6800 in standby awaiting transaction
First left virtual LED is solid green	Contactless transaction started
All four virtual LEDs blink green	Contactless transaction complete
ICC slot LED is on	ICC transaction started
MSD LEDs on	MSR transaction started

6.3. Device State and UI

State	Beep	LCD	Indicating
De-activated	Short beep for 5 seconds	"Deactivated"	Device is in "Manufactory mode;" no security functions enabled.
Activated	No Beeper	"Activated"	Manufactory data and certificate loaded into device, but no working keys.
Common	No Beeper	"Need More Key" "Self-test Fail"	Device activated but not ready for sensitive functions. The reason should be due to missing working keys, device is suspended due to self-test fail or sensitive limitation, etc.
Ready	No Beeper	"Welcome"	Device ready for sensitive functions, like transaction, Get PIN ,GET account, etc.

State	Beep	LCD	Indicating
Tamper	Beeper per 1 second	"Tampered"	Device was tampered by physical, temperature, or voltage attack. All sensitive information is erased or unrecoverable. Device blocks all sensitive function. There is no way to recover except to return to manufacturer.

6.4. Tamper and Failed Self-Check Indicators

The VP6800 displays the following indicators when it has been tampered or has any of the other following internal issues, such as an expired certificate, missing key, or similar fault discovered during a self-check.

Note that the Tampered screen also displays configuration information used to diagnose the cause of the issue, similar to the image below on the right:



Indicator	Tampered Status	Other Issue Status
Virtual LEDs	All Virtual LEDs off	All Virtual LEDs off
LCD Display Message	TAMPERED	See below
Buzzer	Alarm tone	See below

6.4.1. Other Status Messages

The VP6800's LCD can display the following messages for both regular status and in the event of a failed self-check:

State	Buzzer	LCD	Indicating
Tamper triggered	Beeps every 1 second	"Tampered"	Device was tampered by physical, temperature, or voltage attack. All sensitive information is erased or unrecoverable. The reader blocks all sensitive functions. There is no way to recover the reader except to return it to ID TECH.
Certification check fail	No sound	"Cert Fail"	Certificate tree self-check has failed (example of failure: expiration of certification).
Firmware integrity check fail	No sound	"MSRFail"	MSR failure, usually caused by the abnormal state of the MSR module.
	No sound	"FW/BL Fail"	Firmware self-check has failed
Abnormal Key Status	No sound	"Keys Fail"	Encryption key self-check has failed.
	No sound	"Need More Key" "Self –test Fail"	The reader is activated but not ready for sensitive functions. The reason is most likely due to missing working keys, the reader being suspended due to self-test failure, sensitive limitation, or similar causes.
Deactivated	Short beep for 5 seconds	"Deactivated"	The reader is in "Manufactory mode;" no security functions are enabled.
Activated	No sound	"Activated"	Manufactory data and certificate are loaded into the reader, but no working keys.
Ready	No sound	"Welcome"	The reader is ready for sensitive functions like transactions, Get PIN ,GET account, and similar commands.

If your VP6800 is tampered, contact [ID TECH support](#) for assistance.

7. Installation

The sections below describe VP6800 installation.

7.1. Parts List for Development

Verify that you have the following hardware for the installation of the VP6800:

- Cable 80159217-001



Power supply AC0005R-26



7.2. VP6800 Mounting Guidelines and Installation

Mount the unit according to the drawings shown, with #8-32 studs spaced 65mm apart horizontally and 67mm vertically. Use a torque wrench to tighten the screws to 8kgf.

For safety reasons, make sure to mount the VP6800 at a height no greater than two meters from the floor.

Warning: The antenna's RF field is sensitive to the proximity of metal. There are three options for mounting the VP6800 on a metal surface:

- Mount with the RF emitting surface of the antenna at least 1cm *in front* of any metal.
- Mount with the RF emitting surface of the antenna at least 1cm *behind* any metal. **This will reduce the effective range of the antenna and is not recommended.**
- Mount flush with the metal, but allow a minimum of 1cm distance from the metal

Above all else, do not mount the VP6800 in a location where it is surrounded by metal.

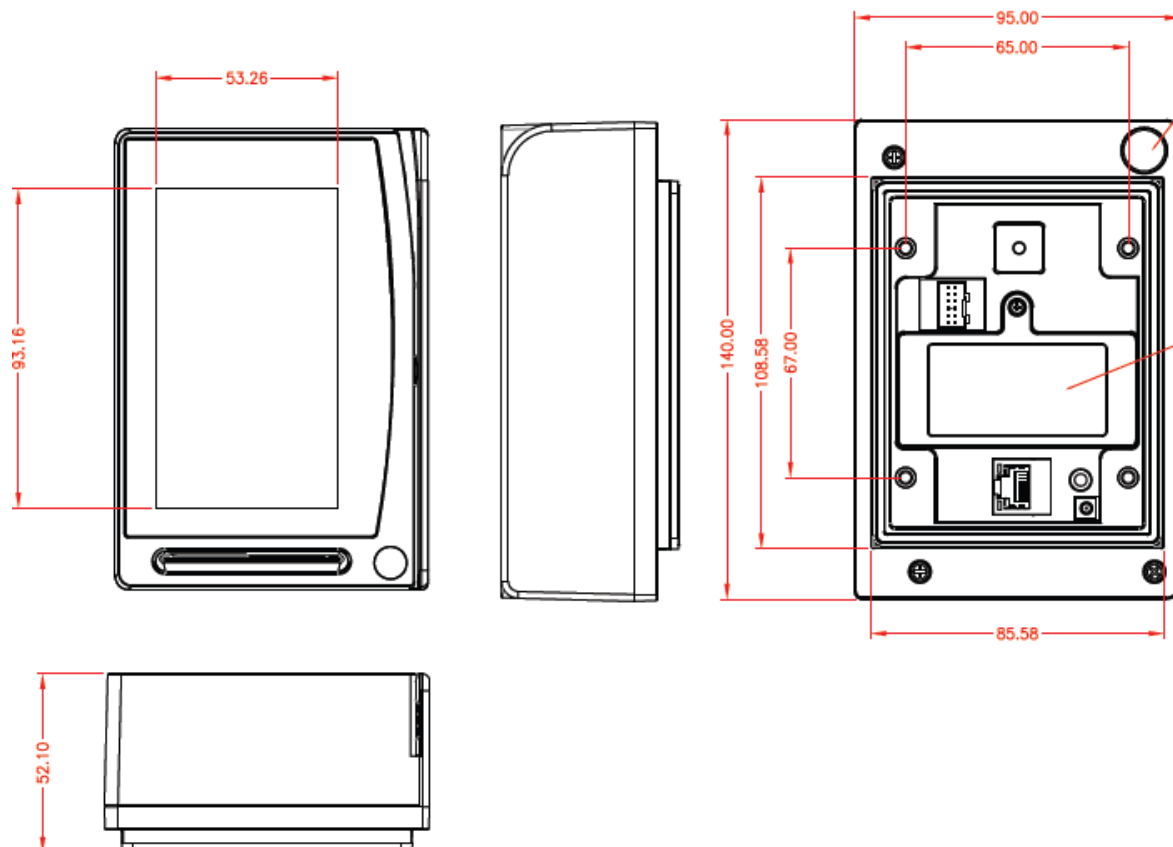

7.2.1. VP6800 Mounting Angle Requirements

The VP6800's ICC card slot is designed with a 15-degree angle (pointed outward) to drain water.

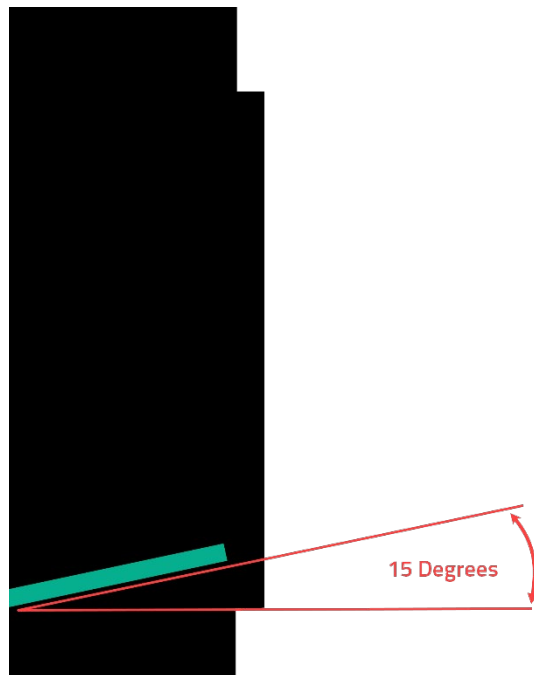

To prevent drainage issues, **make sure the angle between the VP6800 LCD plane and the ground is less than 90 degrees.**

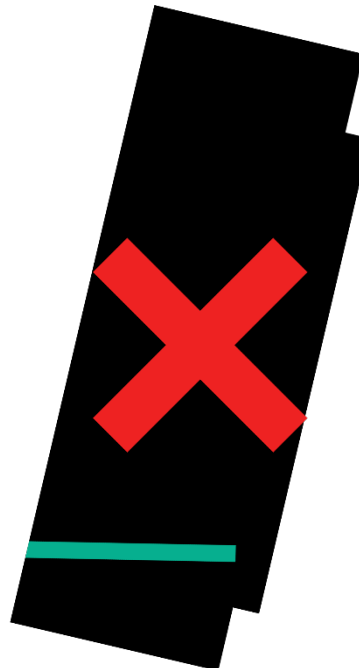

7.3. VP6800 Grounding Requirements

The VP6800 is designed such that it is isolated from the signal noise of other devices and does not require additional grounding. However, to add your own grounding cable, follow the diagrams provided in the [Cable](#) section above. Note that the Shield GND and GND are separate from the cable.

Note: The metal plate on the back of the card swipe area of the VP6800 is not designed for grounding; this plate is used only to prevent wear of the plastic housing during card swipes.

7.4. Connecting Cable and Power

Note: The VP6800 requires a power supply whether connected by RS-232 or USB.



Or connect Ethernet interface.

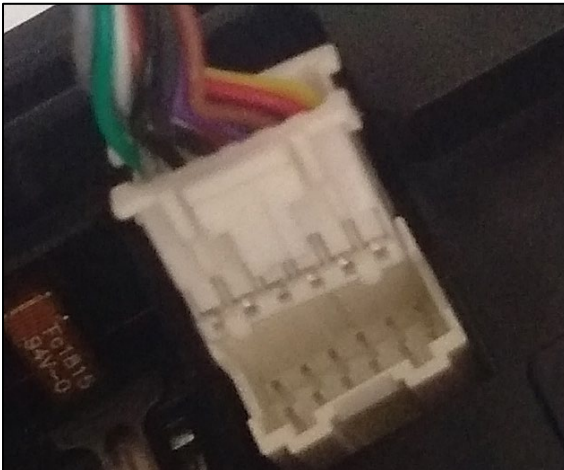

3. Connect the +5VDC power supply to the barrel receptacle on the RS-232 cable. Plug the unit into an AC outlet and verify that the VP6800 lights up.

7.5. Bluetooth Connection

When using Bluetooth communication with the host, follow these steps:

1. Search for Bluetooth name of **VP6800** on the mobile host.
2. Select **Pairing**.

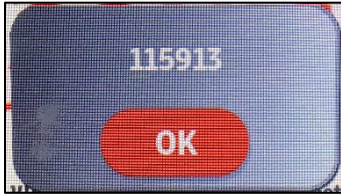

8. VP6800 Configuration Settings

Setting up the VP6800 requires users to enter the main menu **each time they enter a sub-menu, even if they do not save any setting changes.**

Note that users can change many of the settings below via firmware commands. To use firmware commands to configure a VP6800 unit, refer to the *NEO 2 Interface Developer's Guide*, available from your ID TECH representative.

Follow the steps below to access the main menu.

1. Power on the VP6800.



8.1. Configuring Ethernet Settings

Follow the steps below to configure ethernet settings.

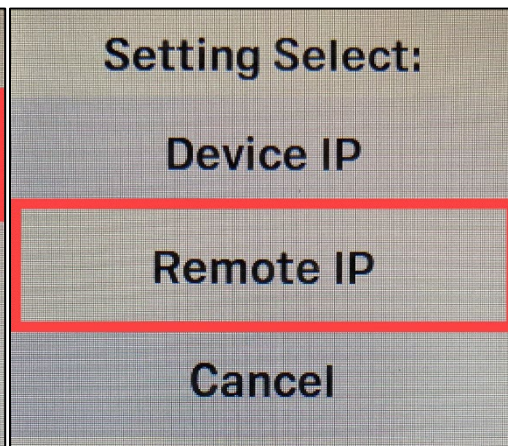
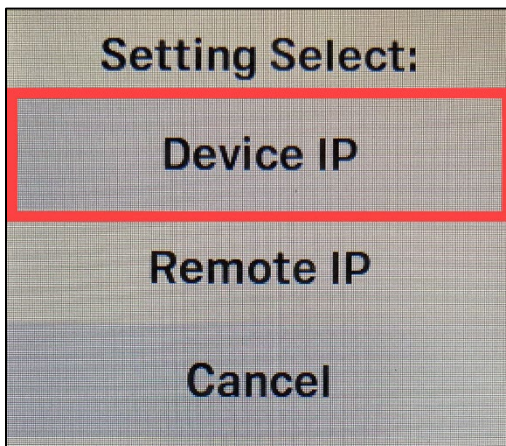
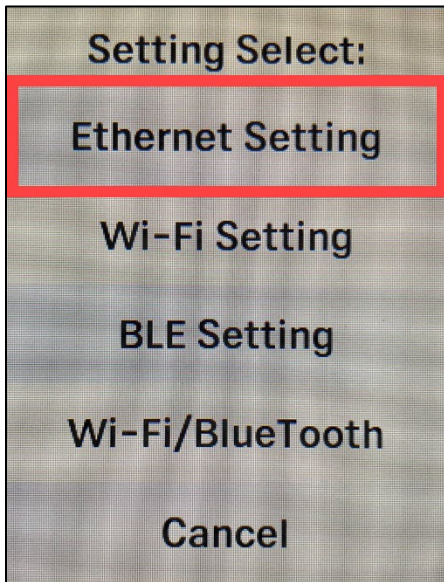

8.1.1. Setting the Device IP

- To set the Device IP, enter IP address information in the field highlighted in blue.

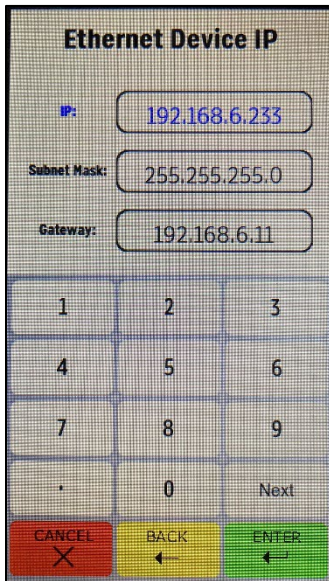

Ethernet Device IP

IP: 192.168.6.233

Subnet Mask: 255.255.255.0

Gateway: 192.168.6.11

1	2	3
4	5	6
7	8	9
.	0	Next

CANCEL BACK ENTER

- Select **Next** to move to the next field.
 - Select **Enter** after completing the configuration to save.
 - To clear a field, select **Cancel**.
 - To exit the menu without making changes, select **Cancel** again.
- The VP6800's screen displays an **IP is Set** dialog on success.

8.1.2. Setting the Remote IP

- To set the Remote IP, enter IP address information in the field highlighted in blue.

ID TECH's Encryption protocol port is **1443**; make sure to enter that number as the port.

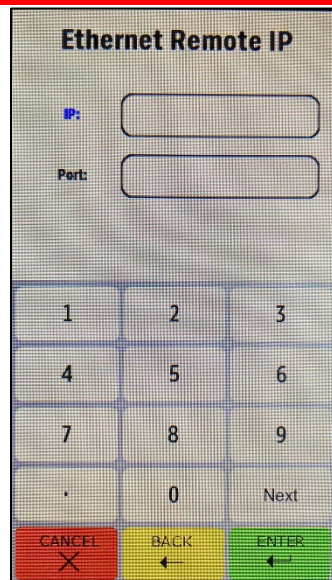

Ethernet Remote IP

IP:

Port:

1	2	3
4	5	6
7	8	9
.	0	Next

CANCEL BACK ENTER

- Select **Next** to move to the next field.
- Select **Enter** after completing the configuration to save.

- c. To clear a field, select **Cancel**.
 - d. To exit the menu without making changes, select **Cancel** again.
2. The VP6800's screen displays an **IP is Set** dialog on success.
 3. Next, on a Windows computer, open **Network & Internet Settings** by right-clicking the internet connection icon in the taskbar.



4. Click **Change Adapter Options**.

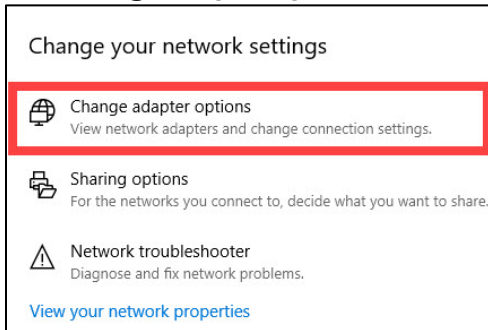

5. Right-click on your Network Connection and select **Properties**.

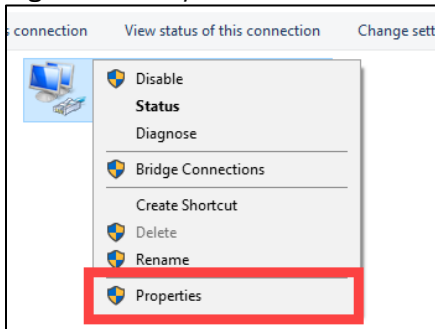

6. Select **Use the following IP address**, enter the required IP information, then click **OK**.

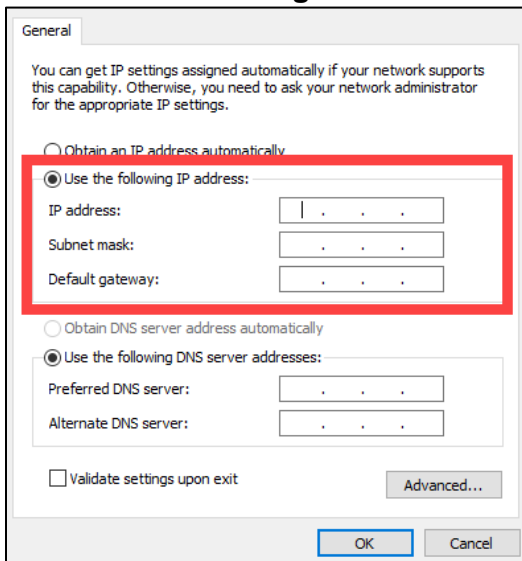

8.2. Configuring Wi-Fi Settings

Follow the steps below to configure Wi-Fi settings.

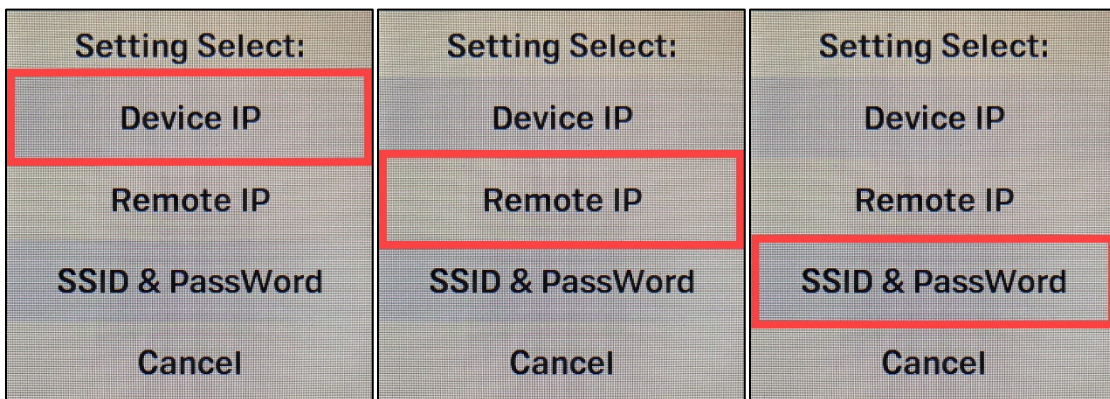
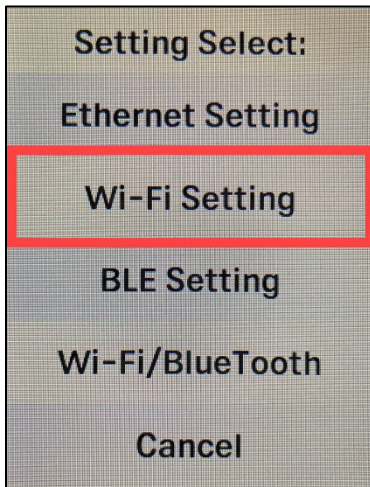

8.2.1. Setting the Device IP

- a. Select **Next** to move to the next field.
 - b. Select **Enter** after completing the configuration to save.
 - c. To clear a field, select **Cancel**.
 - d. To exit the menu without making changes, select **Cancel** again.
2. The VP6800's screen displays an **IP is Set** dialog on success.

8.2.2. Setting the Remote IP

1. To set the Remote IP, enter IP address information in the field highlighted in blue.

ID TECH's Encryption protocol port is **1443**; make sure to enter that number as the port.

- a. Select **Next** to move to the next field.
- b. Select **Enter** after completing the configuration to save.

- c. To clear a field, select **Cancel**.
 - d. To exit the menu without making changes, select **Cancel** again.
2. The VP6800's screen displays an **IP is Set** dialog on success.

8.2.3. Setting the SSID and Password

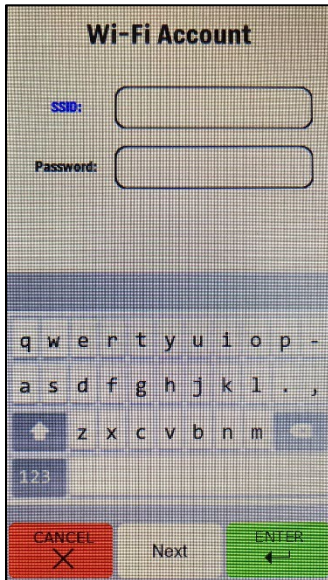

- a. Select **Next** to move to the next field.
 - b. Select **Enter** after completing the configuration to save.
 - c. To clear a field, select **Cancel**.
 - d. To exit the menu without making changes, select **Cancel** again.
2. The VP6800's screen displays an **Account is Set** dialog on success.

8.3. Configuring BLE Settings

Follow the steps below to configure Bluetooth name settings.

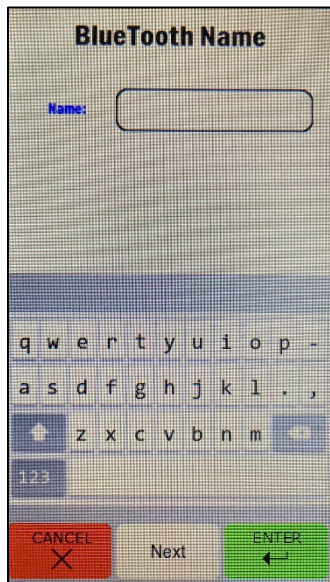
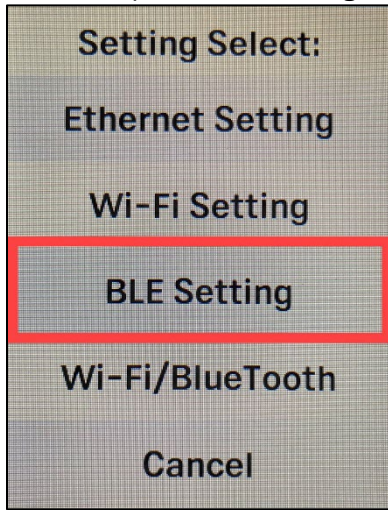

2. Select **Name**.
3. Enter the desired Bluetooth identifier name in the Name field.
 - a. Select **Enter** after completing the configuration to save.
 - b. To clear a field, select **Cancel**.
 - c. To exit the menu without making changes, select **Cancel** again.
3. The VP6800's screen displays a **Name is Set** dialog on success.

8.3.1. Selecting Wi-Fi or Bluetooth

Note: VP6800 units can only transmit wirelessly over one communication format at a time: Wi-Fi or Bluetooth. In addition to the steps below, see the following commands in the *NEO 2 Interface Developer's Guide*:

- **Enable/Disable Communication Port (D2-03)**
- **Set Wireless Work Mode (D1-19)**

When using an iOS device, make sure to enable Bluetooth communication.

Follow the steps below to choose either Wi-Fi or Bluetooth.

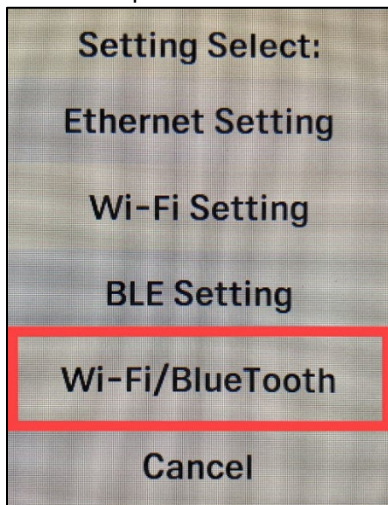

1. Enter the main menu and select **Wi-Fi/Bluetooth**.

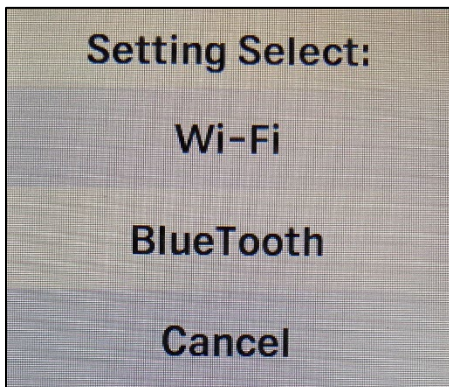

2. Select **Wi-Fi** or Bluetooth to choose the desired communication format.
 - a. Select **Cancel** to exit the menu without making any changes.

9. Security Guide

The VP6800 is an unattended device. Contact your ID TECH representative or send an e-mail to support@idtechproducts.com if you have any questions involving the product's daily use. We recommend you conduct daily checks of the device as follows:

- Check the tamper evidence physical seals, to make sure they are intact.
- Power on the device, check the beeper, and the display message, making sure there is no tamper indication (see earlier chart for beeper interpretation). Also read the firmware version, making sure the firmware version is correct.
- Check the touchpad, to make sure there is no physical overlay on the touchpad.
- Check the appearance of device, to make sure there isn't any hole on the device or suspicious object around the ICC card slot.
- Check the MSR (magnetic stripe) slot, to make sure there is no alteration of the device.

10. Decommissioning PCI-Certified Devices

All PCI devices require proper decommissioning prior to device disposal in order to ensure the protection of all sensitive financial card data. For instructions on decommissioning your device, see [Decommissioning of PCI-Certified Devices](#) on the ID TECH Knowledge Base.

11. Troubleshooting

Consult the [ID TECH Knowledge Base](#) for troubleshooting assistance.

12. 24-Hour Device Reboot

Per PCI Requirements, this device reboots every 24 hours. Please contact your device integrator if you need to check the reboot time for your unit.

13. Firmware Reference

The VP6800 uses ID TECH's NEO 2 firmware. For a comprehensive guide to the device's firmware-level commands, ask your ID TECH representative for the *NEO 2 Interface Developer's Guide* (or IDG). It is available at no charge to customers on request.

14. Software Development Support

To facilitate integration of the VP6800 into vending, POS, and other environments, ID TECH makes available a Universal SDK that enables the rapid development of software apps for the VP6800 using C# on Windows or C++ on Linux. To obtain the Universal SDK, go to the ID TECH [Knowledge Base](#) and choose the VP6800 from the Product page listings. Further information will be available there.

The Universal SDK contains redistributable libraries, sample code, and other materials that will aid you in quickly creating the VP6800 applications, greatly reducing the time spent in configuring the device, parsing transaction data, etc.

15. Updating VP6800 Firmware

The steps below describe the process for updating VP6800's firmware (for both its K81 and RT1050 processors) via the Universal SDK Demo.

Note: Before you begin, contact your ID TECH representative to receive the most recent VP6800 firmware. Download the ZIP file and extract it to your computer.

1. Connect the VP6800 to your PC via USB or serial port.
2. Download and install the latest [USDK Demo app](#) from the ID TECH Knowledge Base (if you cannot access the link, please [contact support](#)).
3. Open the USDK Demo app from the Windows Start menu.

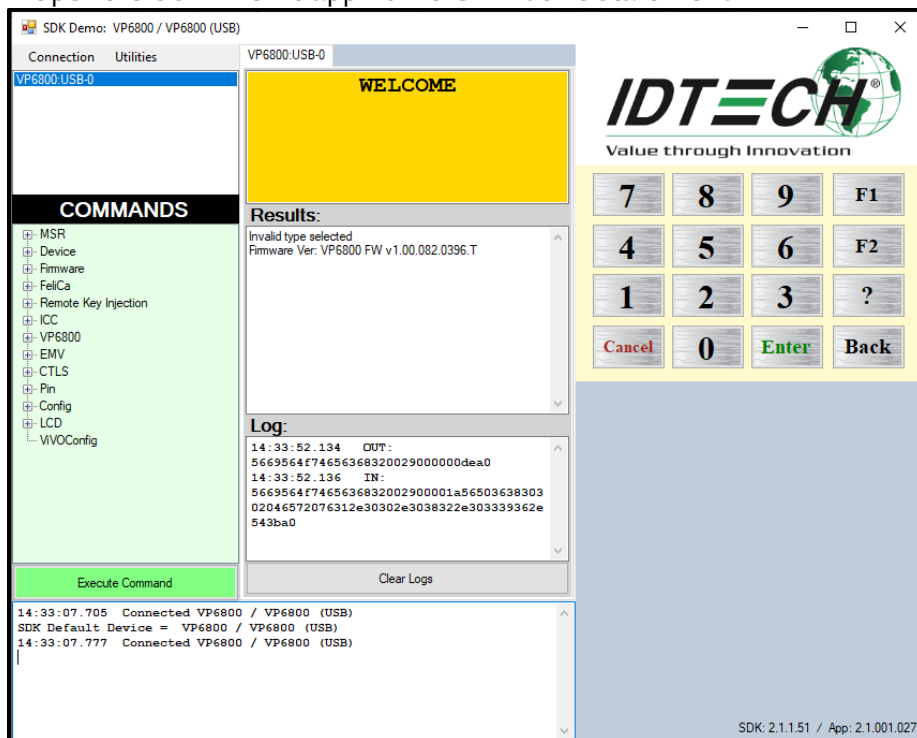

4. Under **Firmware**, select **Update Device Firmware**, then click **Execute Command**.

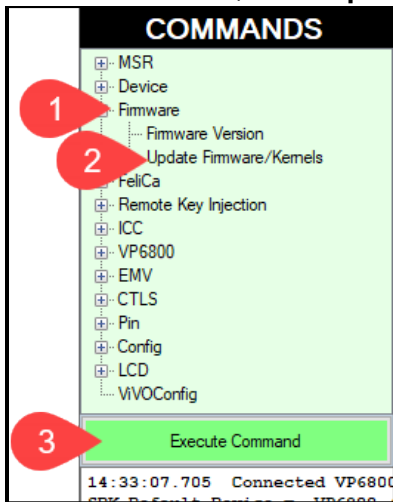

5. In the **Firmware Type** dialog, enter **255** for **K81 FW** and click **OK**.

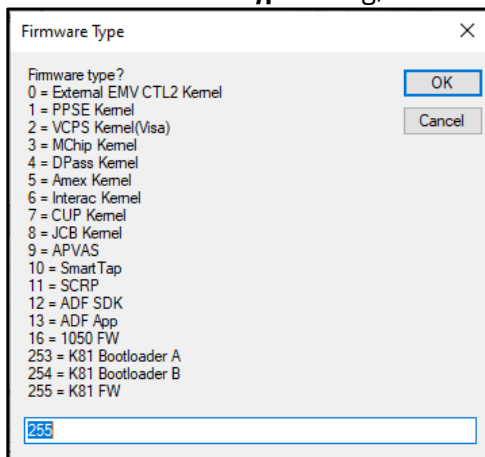

6. In the File Explorer window, navigate to the directory where you saved the K81 firmware update, select the FW file that starts with **NEO_II_vp6800_...** and click **Open**.
7. The VP6800 reboots and enters the bootloader, at which point the USDK Demo app begins updating the device's K81 firmware.

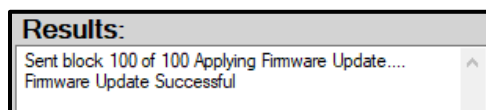

9. Next, to update the RT1050 Firmware select **Firmware**, select **Update Device Firmware**, then click **Execute Command** again.

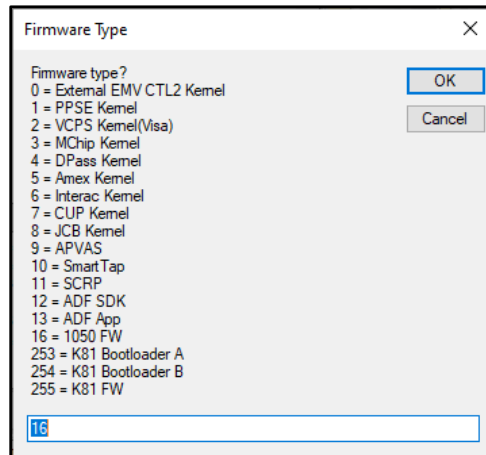

11. In the File Explorer window, navigate to the directory where you saved the RT1050 firmware update, select the RT1050 FW file that starts with **VP6800FW_RT1050_...** and click **Open**.
12. The VP6800 reboots and enters the bootloader again to update the device's RT1050 firmware.
13. When the RT1050 firmware update completes, the VP6800 reboots again and the USDK Demo app prints **Firmware Update Successful** in the **Results** panel.

16. Appendix A: Power Over Ethernet Splitter

In environments that require communication with the VP6800 via powered ethernet, ID TECH offers an optional POE splitter (P/N: 80159280-001).

16.1. ID TECH POE Splitter

Color: Black

Material: SABIC Lexan 925U

POE Splitter SPEC

POE Power input	44-57VDC
POE protocol	IEEE802.3af
Output Power	5V/2.4A (+/- 0.3V Noise/ripple<100mVp-p) Efficiency :70% min Temperature protect
Ethernet Data	10/100M
LED	LED Color: Green Sleep Mode: Blinking Run Mode: Constantly bright
Operating Temperature	-25°C - +70°C (at least 5V/2.4A)
Storage Temperature	-40°C - +80°C
Working Humidity	10%~95%
Storage Humidity	5%~95%
Certifications	FCC part 15 class B/CE/RoHS2
ESD	Contact ±8KV, Air ±10KV
Isolation	1.0KV
Power/Data cables	23cm Length

17. Appendix B: Supported Micro SD Cards

The VP6800 supports a limited number of Micro SD cards; the following cards have been tested and verified for the device:

- Kingston/SDC4/8GB
- Kingston/SDCS/16GB
- SanDisk/micro SDHC UHS-I card/16G